

Vehicle Speed Control Equipped with Special Combinations, Brake System and Safe Distance Measurements

Salameh A. Sawalha

On leave from Faculty of Engineering Technology, Al- Balqa Applied University- Jordan.

Abstract: - It is a system that aims to control vehicle's speed in accordance with the street and road speed limit. The system finds out the whereabouts of the vehicle then it identifies the allowed speed for that particular place. After this, it starts decreasing the speed gradually until it reaches the desirable limit.

When the vehicle runs, The GPS finds the location of the vehicle then it sends the longitude and the latitude to the control unit to identify the speed limit of the street. If it has been found that the vehicle's speed exceeds the limit, a signal will be sent to the brake system to reduce the speed until it drops to the limits.

One of the most important characteristics of the system that it senses the distances between two vehicles by (Ultrasonic sensor) allowing a certain distance between them which is in correspondent to their speed and that results in non- occurrence of accidents and crashes. All of which is done without exceeding the speed limit of streets. If the system fails for any malfunction, a warning message containing the number of the vehicle and information about it will be sent to the traffic department as a feedback.

Keywords: *Digital Brake, Vehicle Speed, Digital Retarders, Speed Control, Safe Distance, Special Combination Brake, Injectors.*

INTRODUCTION

Traffic accidents are increasingly being recognized as a major cause of death and a growing health problem. According to the world health organization (WHO), annually about 1.2 million people killed, and 50 million people injured [1].

The economic cost of road crashes and injuries is estimated to be 1% of Gross National Product (GNP) in low-income countries, 1.5% in middle-income countries and 2% in high income countries. The global cost is estimated to be US\$ 518 billion per year. Low- income and middle income countries account for US\$ 65 billion more than they receive in over all development assistance [2].

The health system spends about 2.2 million Euros (1.3%) of total hospitalizations cost per year for residents in Florence) in treating people injured in road traffic accidents [3].

Traffic accidents can be attributed to human, vehicular, and environmental factors. Human factors have been found to contribute to 57 percent of the accidents in the developed countries. Together with vehicular and environmental factors, human factors account for about 92 percent. In this context, found that 46% and more attributed to the driving exceeding the limited speed [4], [5], [6], [7].

Fatality risk continues to rise. In contrast, fatality risks for different developed countries actually decreased with time, while in some countries are increased. In Saudi Arabia, more than 540000 accidents happened in 2012 (the estimated cost of crashes is excess of \$3.47 Billion), resulted in sixty eight thousand injured, and more than seven thousands deaths (about twenty deaths per day), which is the highest all over the world [6].

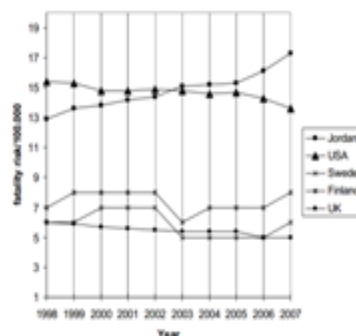

Figure1: Fatality Risk for Different Countries [8].

The competent authorities of traffic in all countries are working to prevent and avoid the traffic accidents, through traffic awareness, legislation and laws, traffic rules and regulations, improvement of roads, traffic services and the imposition of fines and penalties. A lot of researches, studies and patents interested in forcibly controlling the vehicle speed, in addition to the efforts of the industrial companies to provide their vehicle products with modern systems and devices to prevent the traffic accidents and to help driving safely on the road.

Equipping the vehicle with extra safety features has contributed in some cases to reduce the number of accidents, but the increased number of accidents in many countries indicates that until this day the efforts of the inventors, the researchers and the competent authorities of traffic still unable to achieve the desired goal. Speed limit management, control and enforcement continue to be a major concern for the safety of human lives around the globe. Without appropriate action by 2020, road traffic injuries are predicted to be the third leading contributor to the global burden of disease and injury; whereas war related injuries will rank number nine [9].

DRIVING AT SPEEDS EXCEEDING LIMITED: AN OUTLOOK

There are a considerable number of researches, aimed to study the influence of high speed driving, in order to achieve the proper solutions of reducing the traffic accidents and, to decrease the number of injuries and deaths resulting from them.

Mohammed A.Khasawneh et al, suggested a novel approach, relying on intelligent engineering, whereby the maximum speed limit at which vehicles on the road can cruise is controlled from some central or distributed facility (CCF). This approach would decline the rates of speed-related traffic accidents by approximately 65–70% according to existing statistics, as mention in this paper [10].

Figure 2, shows the number of reported accidents as a function of posted speed limit (km/h). Note that accident rates increased in zones where the posted speed limits were in the lower speed limit ranges (30–60km/h) [8].

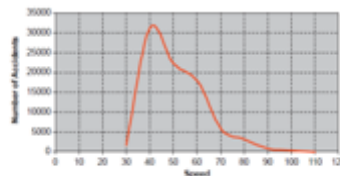

Figure 2: Number of Accidents vs. Posted Speed- Limit [8]

According to Bowie [11], it was reported that data analysis about the dangers of high speed driving, showed the following main conclusions:

- More than half of fatal accidents have occurred at a speed greater than 55Km / h.
- An increase equivalent to each 5Km / h above the speed limit doubled the probability of danger.
- Driving the vehicle at 65Km / h doubled the risk, and at 70Km / h, the risk increased four times.

In the same context, the Swiss Nelson draws a conclusion which is the relationship between speed and fatal collisions. Decrease speeding 3%, reduced the probability of danger at rate 12% [12].

Speed is cited as a related factor in 30% of fatal crashes and 12% of all crashes in the USA [13].

Dipaola J, Dobson R and Morse C designed a pre- programmed digital computer installed in the car which controls the speed [14].

Mercedes-Benz have speed limit assistant, which detects speed-limit signs in milliseconds, in real time, and reminds the driver of the current speed limit. The system based on intelligent, electronic image processing [15].

Speed humps prevent drivers to drive in a higher speed in specific locations like, building parks and service stations. These humps made in different shapes, sizes, and colors [16].

METHODOLOGY

Finding the appropriate solution to force the driver to drive at a reasonable speed remains the most important issue to reduce the number of traffic accidents.

Reducing the vehicle speed can be achieved by controlling the fuel amount entering the engine (through: injection system, throttle valve position, and fuel pump), or by changing the brake system mechanism.

As known the amount of fuel injected to the combustion chamber in most types of engines is being computed in the Engine Control Unit (ECU) through many factors which are [17]:

- RPM sensor.
- Crankshaft position sensor.
- Battery voltage sensor.
- Air flow sensor.

- Throttle Position (TPS) sensor.
- Oxygen sensor.

The use of the fuel pump to control the speeds is not suitable because it pumps the fuel continuously, and sometimes more than the needed quantity. In addition, it contains a back line to cycle the excess fuel back to the fuel tank. This may result in errors and failure in the engine cycle, which causes knocking and extra fuel consumption.

By using TPS (throttle position sensor) signal to reduce speed, the air ratio will be more than the fuel ratio, which will lead to lean phase of combustion. As a result, the engine vibrations will rise and will increase the chance of failure.

Taking into consideration the importance of the time required reducing the speed and nature of the road (flat or downhill), we cannot rely on the throttle valve as one of the appropriate solutions, because while driving on a downhill road, the vehicle will continue accelerating even when the throttle valve is completely closed.

It may seem at first glance that the control of the fuel through the injection system is one of the most appropriate solutions to control vehicle speed, because the injection system is the direct controller which controls delivering fuel to the combustion chambers.

That's mean, reduce the fuel amount injected to the combustion chamber, can be achieved by controlling signal from the injection system to the ECU. The second solution is applying brake in milliseconds which is achieved by using an automatic brake system to decrease the response time to get immediate deceleration.

In this paper a system that aims to control vehicle's speed, based on GPS and, equipped with a special combination brake system, injection system and safe distance measurements.

SYSTEM OVERVIEW

Figure 3, shows the block diagram of the system, which consists of the following:

1. GPS (Global Positioning System).
2. Ultrasonic module.
3. Control unit (PIC microcontroller).
4. Vehicle speed sensor.
5. Bipolar stepper motor.
6. GSM modem.
7. Control circuit that consists of relay and transistor.
8. Some peripherals needed to operate microcontroller.

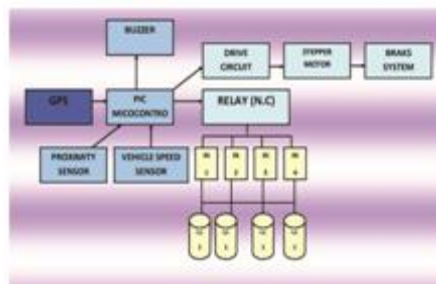

Figure 3: The Block Diagram of the System.

Ultrasonic sensor generates high frequency sound waves and evaluates the echo which is received back by the sensor. It calculates the time interval between sending the signal and receiving the echo to determine the distance to an object. The ultrasonic sensor always senses objects and calculates distance between them and the speed sensor measures vehicle speed and sends it to the microcontroller to deal with it.

When the vehicle enters a street with a speed limit of 90Km/hr (for example), the GPS receiver provides the location (longitude and latitude) of it and sends a signal to PIC microcontroller. The speeds of each street are stored in the microcontroller as a database, so it determines the street speed and analyzes data to match it. If the actual speed is greater than speed limit, the injectors will stop the fuel injection through the N.C relay, and the control unit immediately sends a digital signal to a stepper motor which is connected to the brake system. The digital signal moves the stepper motor through certain number of steps which are determined by calculating the necessary braking value to reduce the vehicle's speed to the required extent.

To achieve a safety distances in varies speeds, the sensor senses the existence of a vehicle on variable distances relying on its variable speed. Then, the sensor determines whether or not the distance is safe depending on the vehicle's traveling speed. Up to this point, future results are to be determined in accordance to the vehicles speed and the distance between the two vehicles. Such process is needed for a decision to be taken which controls the vehicle's speed depending on the required safe distance.

Figure 4, shows the flowchart of the system. Once the system starts functioning, the buzzer gives a sound as a notice to the beginning of that function.

The same process occurs when the Ultrasonic sensor (proximity sensor) gives notification to the control unit if the distance measuring between the two vehicles was less than a certain limit, which depends on the distance sensor specifications.

1. GPS (Global Positioning System) receiver.
2. PIC Microcontroller (PIC 16f877a).
3. Vehicle Speed Sensor.
4. Ultrasonic Module (HC-SR04).
5. Bipolar Stepper Motor.
6. Drive Circuit (ULN2803).
7. GSM modem.
8. Transistors (NPN).

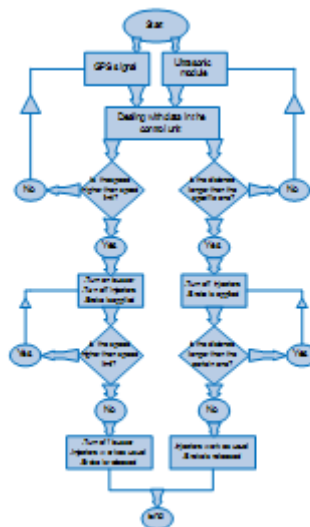

Figure 4: The Flowchart of the System.

Figure 5, shows the Circuit Diagram of the Control System, which consists of the following components:

9. Buzzer.
10. Normally Closed Relay.
11. Capacitors (22MF).
12. Resistors (1K, 10K).
13. Crystal Oscillator (4MH).
14. 5 volt Power supply.
15. 12 volt Power supply.

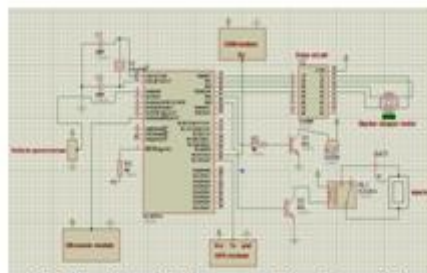

Figure 5: The Circuit Diagram of the Control System.

SIMULATION

The system was simulated on Proteus software. By simulating hardware *actions*, the future results must indicate: response of system, time of response, mechanism of control like applying brake mechanism and controlling injectors. In simulation, the system appears in five modes.

- **The first mode**

Figure 6, shows the circuit diagram when the vehicle is turned off, we notice that all pins appear in blue except MCLR pin, this because this pin is supplied by external power supply.

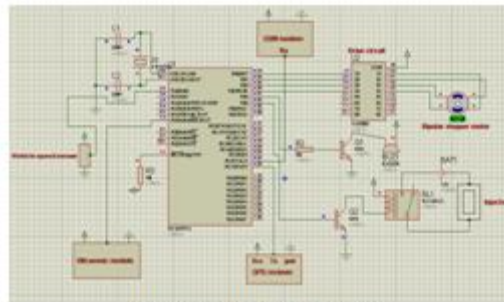

Figure 6: The First Mode.

- **The second mode**

Figure 7, shows signals in a normal driving. P7 of port C and P0, P5 of port A look in red. This means that the GPS receiver always provides latitude and longitude of the region or the street to the microcontroller. The ultrasonic sensor always senses and calculates distance between the car and the following one.

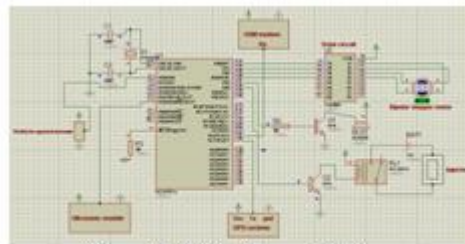

Figure 7: While Normal Driving.

- **The third mode**

After the GPS picks up latitude and longitude and the control unit process data, the speed limit is determined by microcontroller and a decision will be taken. For the purpose of reducing vehicle speed to the speed limit, the control unit sends signals to turn off injectors, at the same time a buzzer gives audio as reminder that the system is working and the brake is applied. The VSS (vehicle Speed Sensor) signal is a very important feedback to let the microcontroller determine if the speed reaches the required speed (figure 8).

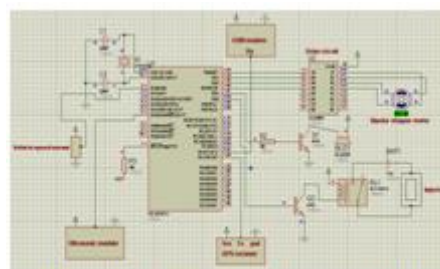

Figure 8: When speed exceeds speed limit.

- **The fourth mode**

If the vehicle speed reaches the ideal speed, the buzzer, injectors and brake will be back to function normally and the ultrasonic sensor remains calculating distances to get the appropriate safe distance (figure 9).

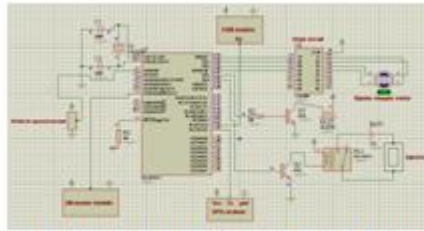

Figure 9: The System Back To Its Normal Function.

- **The fifth mode**

Figure 10, shows P6 of port c in red, this means that a warning message was sent to the traffic department when the system fails to inform it of that.

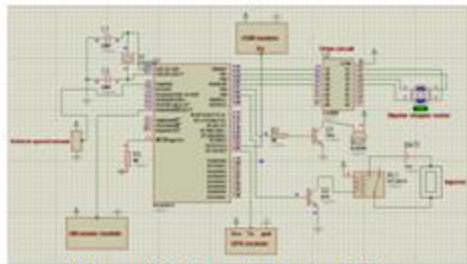

Figure 10: When the System Fails.

DISCUSSION AND RESULTS

The time required to reduce the vehicle speed can be calculated by the following equation:

$$\text{Total deceleration time} = \text{perception and reaction time} + \text{braking time} \quad (1)$$

Highway traffic and safety engineers have some general guidelines which have been developed over the years and hold now as standards. As an example, if a street surface is dry, the average driver can safely decelerate an automobile or light truck with reasonably good tires (with reasonably good coefficient of friction of about .75) at the rate of about 4.5 meter per second (m/s²). That is, a driver can slow down at this rate without anticipated probability of controlling the vehicle which will be lost in the process [18].

This means that the skilled driver could easily get deceleration rates in excess of 3.4 m/s² without loss of control. It is very possible and probable that with some efforts, the driver that attempts to be aware of braking safety procedures and practices can and should get much better braking (safely) than the guidelines used nationally, approaching that of the professionally driver published performance tests.

We calculated the time that required reducing vehicle speed such 10 Km/h in the following three cases:

Case 1: Traditional Brake System

The average mechanical braking time, which is required to reduce the vehicle speed about 10km/h mechanically, equals to 0.62 s, and the average time of the driver's perception time and reaction time equals to 2.54 s, the time needed to the total reduction equals to 3.16 s [18].

Case 2: Automatic Brake System without the effect of injectors

After adding this system to the vehicle and connecting it to both: the injection system and the brake system, the process of reducing speed becomes faster because it does not require any follow-up of the driver. The time required receiving a signal by GPS ranges between 0.6 to 0.9 s, and it varies depending on the communications network in the area. The full process is performed before the arrival of the vehicle into the street and then the vehicle will not exceed the upper speed limit in the street; this because of the pre- programming of the system and the high accuracy of the GPS that make the process begins before it reaches the street.

The total time required to reduce speed using vehicle speed control system can be calculated by the following equation:

$$t_{\text{total}} = t_{\text{GPS}} + t_{\text{injectors}} + t_{\text{stepper}} + t_{\text{braking}} \quad (2)$$

Where,

t_{total} : the total time of deceleration

t_{GPS} : the time needed by the GPS to receive the signal.

$t_{\text{injectors}}$: the time needed by the microcontroller to close the injectors.

t_{stepper} : the time needed by the microcontroller to fulfill the task of the stepper motor.

t_{braking} : the braking time with injection system control.

According to the experiments performed in the laboratories of the Northern Border University the time that the GPS takes to determine the position and send it to the control unit equals to 0.66 s, the time required to close injectors is 0.21 seconds, and the time required to apply brake system by a stepper motor is 0.15 s.

So the time required to analyze the signal and begin the process of reduction is equal to 1.02 s.

The mechanical braking time is the same in all cases which equals 0.62 s. So the total time required for decreasing speed such 10 Km/h does not exceed 1.64 s.

Case 3: Injector's Effect

Closing injectors increases the efficiency of the system because it works to prevent the flow of fuel and arrival it to the cylinders, therefore, the time required to reduce speed will be decreased.

In this system, there is an automatic braking system controlled by a stepper motor circuit in a time was calculated previously which was 1.64 s. So actually the time required to reduce the speed 10 km/h must be less than 1.64 s because of the involvement of injectors in the process which increases the efficiency of the braking process.

According to experiment readings, the time required to reduce the vehicle speed such 10 km / h by closing injectors only can be calculated by the following equations [19]:

$$v_2 = v_1 - a \Delta t \quad (3)$$

$$(v_2)^2 = (v_1)^2 - 2 a \Delta s \quad (4)$$

Where,

V_1 : initial velocity (Km/h).

V_2 : final velocity.

Δt : taken time.

ΔS : traveled distance.

a: deceleration

When the vehicle is operated on the empty load -ideal speed during a movement on a straight road and the fuel has been cut off, it continued travelling 577.5 meter before stopping completely ($v_2=0$) [20] . By compensating v_1 as 70 Km/h, v_2 as 0, and ΔS as 577.5 meter in equation 5, the deceleration will be equal to 4.24 m/s².

If the time required in the mechanical braking process to reduce speed 10 km / h is equal to 0.62 s, and the time required to be reduced by shutting injectors only is 2.358 s, the ratio between the effect of injectors and a mechanical braking effect will be 26.3 %.

This means that the vehicle decelerates in rate of 4.24 m/s² and the effect of injectors is 26.3 % of the total of deceleration. In other words, the effect of injectors is equal to 0.263 of the influence of mechanical braking.

The time required for mechanical braking equals to 0.62 - (0.62 *0.263) = 0,457 s. So the total time (with the effect of injectors) = 1.02 + 0.457 = 1.477 s.

SAFE DISTANCE EXPERIMENTS AND CALCULATIONS

In some countries such as the UAE, an instant violation is imposed for not leaving enough distance between vehicles. The director of Dubai police stated "vehicles travels on a speed of 40 km/h have to leave a distance of 35 meters which is equivalent to seven cars' he added 'and when a vehicle's speed is 120 km/h a distance of 104 meters have to be kept"[21].

The safety distance is calculated by multiplying the tenth of the speed indicator with 6. Meaning, if a car travels on a speed of 40 km/h, the safety distance must not be less than 24 meters. We adopted this rule in calculating the safety distance for each speed from 10 to 180 (Km/h), assuming that the following vehicle will stop in any moment (figure 11).

If the deceleration rate of the vehicle varies, the safe distance between vehicles depends on the speed will vary.

It is calculated by the following equation [22]:

$$S = v \delta + v^2/2 d_f - v^2/2 d_l + N L + x_0 \quad (5)$$

Where:

v = initial speed of two vehicles

d_l = deceleration rate of the leading vehicle

d_f = deceleration rate of the following vehicle

δ = perception-reaction time of the following vehicle

x_0 = safety margin after stop

L = length of vehicle

N = number of vehicles in a train

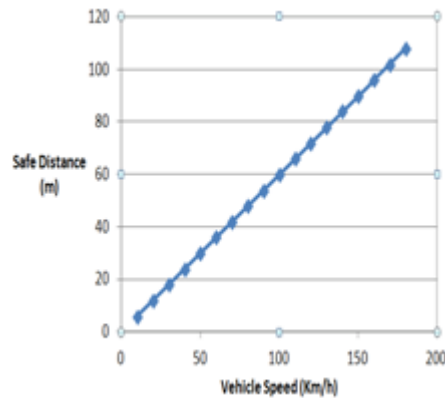

Figure 11: The relation between the vehicle speed and the safe distance for constant deceleration rates of the leading and the following vehicles.

The deceleration rate varies depending on the system used to reduce speed. There are three cases in which the safe distance changes according to the deceleration of the leading vehicle change:

Case 1: when using the traditional brake system, the deceleration of the leading vehicle equals 4.24 m/s^2 .

Case 2: when using an automatic brake system without the effect of injectors, the deceleration of the leading vehicle is 6.096 m/s^2 .

Case 3: when using the automatic brake system with the effect of injectors, the deceleration of the leading vehicle equals 6.77 m/s^2 .

Figure 12, shows the relation between safe distance and vehicle speed for different deceleration rates of the leading vehicle.

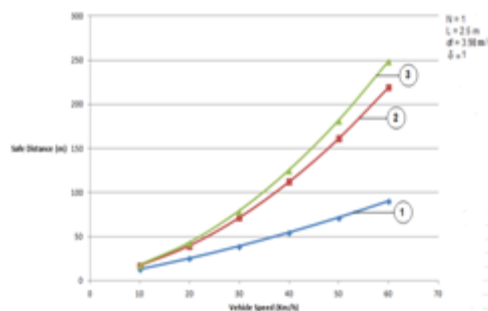

Figure 12: The relation between the safe distance and vehicle speed for different deceleration rates of the leading vehicle.

We notice that the safe distance values are closed to each other, but are not similar because of the leading vehicle deceleration change in all cases.

On Highway roads, if we want to fix the safe distance for speeds from $90 - 180 \text{ Km/s}$, the safe distance is calculated by the following equation [23]:

$$S = 1/k \quad (6)$$

Where:

S: Safe distance in meters.

K: Traffic stream concentration in vehicles per kilometer

The average stream concentration on highway roads equals 62 vehicle/ Km [24]. Hence, the safe distance will equal approximately 16 m .

By using the automatic brake system with the effect of injectors, the required time needed for keeping the safe distance between two vehicles about 16 meter will vary if the vehicle speed varied (figure 13).

CONCLUSION

As a general illustration, the research proves the possible availability for a technological intervention

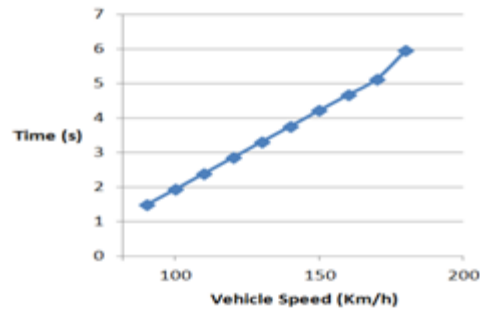

Figure 13: the relation between the vehicle speed and time required for keeping constant safe distance.

factor when humans fail to control their behaviors. The tremendous negative consequences which sometimes surf due to such behaviors are devastating.

The system takes 1.477 seconds to reduce speed 10 Km/h without any intervention of the driver, while it takes 3.16 seconds using traditional braking system. This means that by adding this system, the collision will be reduced significantly, the driving will be easier than using the traditional brake system especially with using injector's control, and the road for drivers and passengers will be very safe because of the existence of property which saves safe distances between vehicles.

What would happen if the driver could not control vehicle's speed? What would be the results if people do not feel safe on the road? Or how much financial losses collisions might cause? This system does not only protect lives but also treasures it.

REFERENCES

- [1] United Nations World Health Organization (WHO), "World Report on Road Traffic Injury Prevention", 2004, Geneva, Switzerland.
- [2] Dinesh Sethi, Francesca Racioppi and Francesco Mitis "Youth and road safety in Europe" ,Policy briefing, WHO European Centre for Environment and Health, WHO Regional Office for Europe, pages 45, Italy, 2007.
- [3] Road traffic accidents in an urban area: linkage between municipal police data-base and routinely collected medical data to assess adverse health effects, health system activities and costs, Barchielli A, Balzi D, 2007.
- [4] Road Traffic Injuries in Saudi Arabia, and Its Impact on the Working Population, Mohamed A. Elshinnawey, Lamiaa E. Fiala, Mostafa A.F. Abbas*, Nabil Othman, 2008.
- [5] Epidemiology of road traffic injuries in Qassim region, Saudi Arabia: Consistency of police and health Data, Issam Barrimah, Farid Midhet and Fawzi Sharaf, International Journal of health and Sciences(IJHS), Vol.6(1), pp31-41 Qassim university, 2012.
- [6] The Saudi Interior Ministry, Traffic Department: Traffic Reports [online][accessed 2013], available from www.Saher.gov.sa.
- [7] Nathan Naylor "Nearly 50% of All Drivers Believes: speeding is a Problem on U.S Roads" ,December,2013, National Highway Traffic Administration.
- [8] Hashem R. Al-Masaeid, Traffic Accidents in Jordan,(2009), Jordan Journal of Civil Engineering, Volume 3, No.4, pp. 331-343
- [9] Khasawneh M., et al., A Wireless infrastructure for tele-traffic speed control, September 2006, Report submitted to King Abdullah II Fund for Development (KAFD).
- [10] Mohammad A. Khasawneha , Mohammad I.Malkaw., Munzer S., Sa'ed M., Haytham Z. El-Shyoukh, Sa'ed M. Hayajneh, Hadeel Y. Qasaimeh, (2009), A security- mbedded infrastructure for Tele-Traffic Speed Control, Journal of t he Franklin Institute, Volume 346, Issue 5, June 2009, Pages 431-448.
- [11] N.N. Bowie, Jr., M. Waltz, "Data Analysis of the Speed-Related Crash Issue, and Traffic Safety", vol. 2, winter 1994, Auto Bureau of Transportation Statistics, U.S. Department of Transportation.
- [12] Nilsson, G., "Traffic Safety Dimensions and the Power Model to Describe the Effect of Speed on Safety", PhD Thesis, Lund Institute of Technology and Society, Traffic Engineering, 2004, Lund, Sweden.
- [13] S. C. Tignor and D. Warren, "Driver Speed Behavior on U.S. Streets and Highways", Compendium of Technical Papers, Institute of Transportation Engineers, 1990, Washington, DC.
- [14] Dipaola J, Dobson R, Morse C, " Car retarder control system", Patent No. US3844514, 1974, USPTO.GOV.
- [15] http://www.emercedesbenz.com/Nov08/12_001505_Mercedes_Benz_TecDay_Special_Feature_Lane_Keeping_Assist_And_Speed_Limit_Assist.html .

- [16] Systemax company, Speed Bump, Available from URL <http://www.globalindustrial.com/c/outdoor-grounds-maintenance/parking-lot/speed-bumps>
- [17] The Internal Combustion Engine in Theory and Practice, Charles Fayette Taylor, Revised edition, 1985
- [18] Akhilesh Kumar Maurya, Prashant Shridhar Bokare” Study Of Deceleration Behaviour Of Different Vehicle Types”, International Journal for Traffic and Transport Engineering, 2012, 2(3): 253 – 270.
- [19] R.C.Hibbeler “Engineering Mechanics – Dynamics”.12th Edition, 2010.
- [20] Salameh Sawalha,Jawadat Al-Jarrah,Ali Dbean Al- Rashidy” System to Control the Vehicles During the Chasing”, International Journal of Mechanical Engineering (IJME),Vol.2,Issue 4,pp 87-98,2013.
- [21] <http://arabic.arabianbusiness.com/business/transportation/2009/dec/21/33476/>
- [22] Jan Valentin, “Traffic flow theory”,lecture notes, www.learningace.com.
- [23] Yufei Yuan, Hans van Lint, Femke van Wageningen-Kessels, Serge Hoogendoorn "Lagrangian Traffic State Estimation For Freeway Networks", 2nd International Conference on Models and Technologies for Intelligent Transportation Systems, 22-24 June, 2011, Leuven, Belgium.
- [24] Norman W. Garrick, Traffic Stream Flow Equations”, lecture notes, www.learningace.com.